

DA-052 REMOTE WHISTLE AND DA-052WV (WITH VOLUME CONTROL) INSTRUCTIONS

DA-052 REMOTE WHISTLE INSTALLATION:

1. Unplug Drive-Alert Control Panel
2. Connect the DA-052 or DA-052WV wires as shown below in Diagram "A"
3. Connect the **BLUE** wire (-) to the Drive-Alert Control Panel's **NEG** Terminal
4. Connect the **BLACK** wire (+) to the Drive-Alert Control Panel's **NO** Terminal
5. Whistle Switch must be "ON" at all times (if equipped on the Drive-Alert model you choose)

Diagram A

DA-052 & DA-052WV Remote Whistle Connection

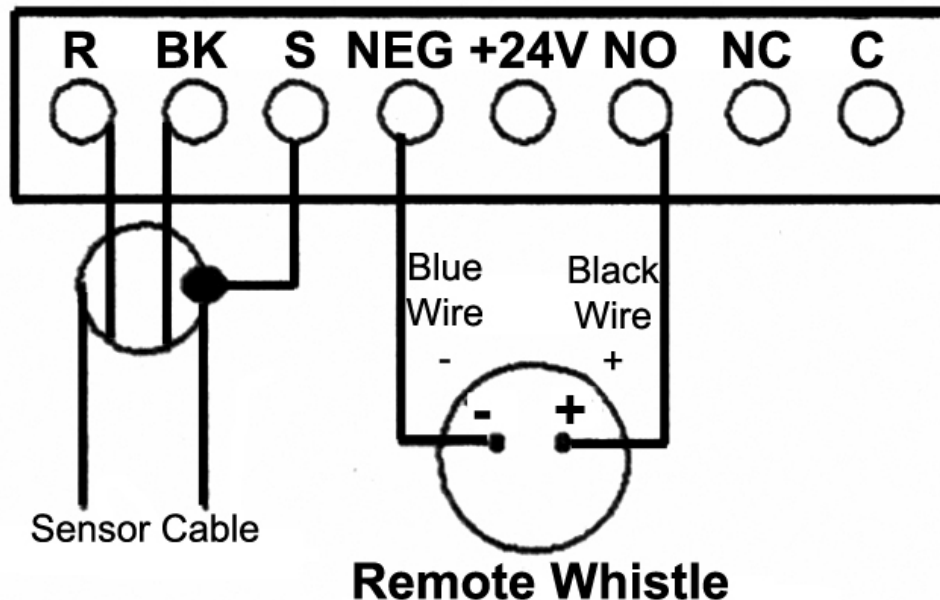



DA-052 and DA-052WV Remote Whistles' Kit Limited Warranty:

Mier Products, Inc.'s Limited Warranty Program, for Drive-Alert models and accessories, protects the original owner for one year from the date of purchase against defects in original parts or workmanship. Mier Products, Inc. agrees to repair or replace parts (Mier's option) that are deemed defective by our Quality Control Team, without charge for parts or labor, if the defective unit is returned prepaid to Mier Products, Inc., Kokomo, IN, 46901, within the one year period.

Close inspection at the time of receipt by the customer will quickly determine product quality. Thus, Mier Products, Inc. recommends inspection of Drive-Alert models and accessories immediately upon receipt and contacting Mier Products, Inc. if quality issues arise.

Mier Products, Inc. does not assume responsibility for claims or damages caused by improper installation or use of these products, accessories, and/or products connected to or stored within them. Mier Products, Inc. does not assume responsibility for damages to these products or their accessories due to shipping damage or damage occurring while in a customer's warehouse and/or possession. Mier Products, Inc. does not assume responsibility for damage due to accident, faulty wiring, overload of Drive-Alert or Drive-Alert accessory output, or components attached to the Drive-Alert parts.

Drive-Alert models and accessories must be shipped, handled, stored, and installed with strict adherence to OEM installation instructions.

This warranty constitutes the entire warranty with respect to Mier's Drive-Alert Models and Accessories and IS IN LIEU OF ALL OTHERS, EXPRESSED OR IMPLIED, INCLUDING ANY WARRANTY OR MERCHANTABILITY AND WARRANTY OF FITNESS FOR A PARTICULAR PURPOSE AND IN NO EVENT IS MIER PRODUCTS, INC., OR IT'S OEM PARTNERS, RESPONSIBLE FOR ANY CONSEQUENTIAL DAMAGES OF ANY NATURE WHATSOEVER.

Any warranty OR sales questions should be directed to Mier Products at 800-473-0213, or via e-mail to info@mierproducts.com

Repair work not covered by this Warranty is available for a nominal charge.